

AUSTIN FARM

Academy

Newsletter 08/11/2024

Dear Parents/Carers,

The children have come back this week with exciting stories of trick and treating & Halloween parties, it sounds like you all had a busy half term! Despite being tired instead of rested from half term, they have still managed to work hard in classes, please see below for what they have learnt this week.

There have been lots of other things happening this week too:

We had a special bonfire night lunch on Tuesday, the banging burgers and veggie sausage rolls were a hit!

On Wednesday, we had flu vaccinations in school for those of you who opted in to this service.

Year 4 completed their first week of swimming lessons and have already come on in leaps and bounds; we can't wait for next week!

Today, the 19 children from years 2-6, who achieved their AR targets last half term had some golden time with me outside - see photos below of them enjoying their reward. Reading is the key to all learning, so let's try to get more children reading at home and quizzing this half term so they achieve their targets before Christmas.

New sporting afterschool clubs forms will come out tonight at 6pm via Teachers2parents; both clubs run from 3.15 - 4.15 and as we subsidise them they only cost £1 a week for free school meal children and £2 a week for everyone else - this is still a bargain!

Monday will be Football club for Foundation, Years 1, 2 and 3. (11/11/2024-16/12/2024)

Thursday will be Netball/Basketball club for Years 3, 4, 5 & 6. (14/11/2024 - 19/12/2024)

As well as the sports clubs starting next week, there are a lot of other school events to be aware of...

Year 4 are swimming again all week; this will be their second week out of three.

On Monday, it is Remembrance Day, and the last day we will be selling poppies from the school office. We will mark it by having a 1-minute silence at 11am and a whole school assembly in the afternoon.

On Tuesday, it is school uniform as usual, but please wear odd socks to celebrate our individuality for anti-bullying week.

On Wednesday and Thursday from 3.30 - 6.00pm, there are parents' evenings for all classes, please take this opportunity to look at your child's work and discuss their learning with their class teachers. It is so important to show your children we are a team and that we all value education and you can also be given some tips about what you could do at home to support them with practising their skills.

On Friday, it is Children in Need day - the children can come to school in mufti and wearing something spotty - this could be socks, a hair accessory or full Pudsey costumes! Please donate via the special ParentPay page that has been set up, just follow the link that your teachers

I hope you have a lovely weekend,



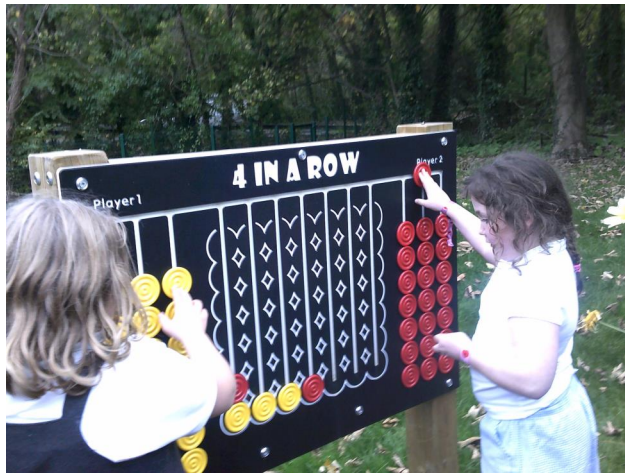

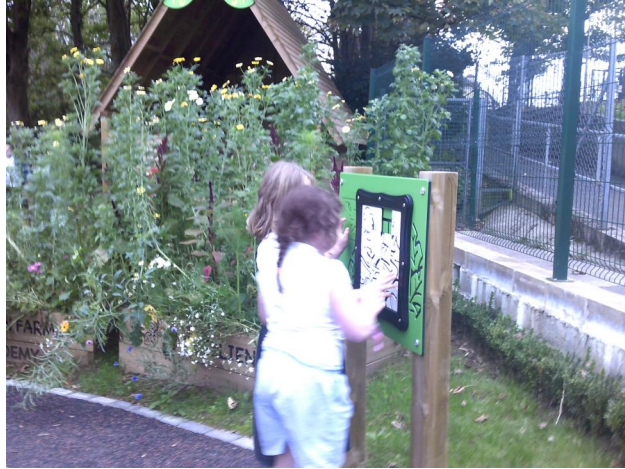



1 - There is still time to sign up to the Schools Challenge (Plymouth Half Marathon-Sunday 11th May 2025 - KS 2 only)
<https://forms.office.com/e/tSP1kCtwZ2>



2 - Asda's Cashpot for Schools initiative, fronted by Joe Wicks, launched on 2nd September, and has hit the landmark figure of £3 million raised for primary schools across the UK – with another eight weeks left to go.

The supermarket kicked off each school fund with £50 and in addition is topping up each school cashpot with an extra £1 for every customer that selects their school via the Asda Rewards app – with no impact on the customer's own Asda Rewards Cashpot. Shoppers and schools can also see the running total that has been raised for their school in the app once they have opted in.

Signing up for the initiative is simple – with customers simply required to opt into Cashpot for Schools in the app and select their school of choice. Cashpot for schools in the app. As well as encouraging parents to sign up – schools are encouraging their entire community to support them – as the initiative is open to all.

Foundation & Year 1: We have been doing lots of art and craft activities linked to Bonfire night including: fireworks printing, rocket making and using our funky fingers to create firework pictures with stickers. We have also started our new unit in history, where we created a timeline of our lives so far. We have also been grooming pets at our Austin Farm groomers linked to our new text How to Wash a Woolly Mammoth.



Year 2: In our Design Technology this week, we began our new unit called 'Wheels and axles'. We explored a range of moving vehicles and then drew a diagram to label the wheels, axle(s) and axle holder(s). At the end of the lesson, the outcome of the unit was shared with us. We have been tasked with making Father Christmas a moving vehicle to help him to deliver his presents as his sleigh isn't working - we hope we can come up with some great designs to help him!!

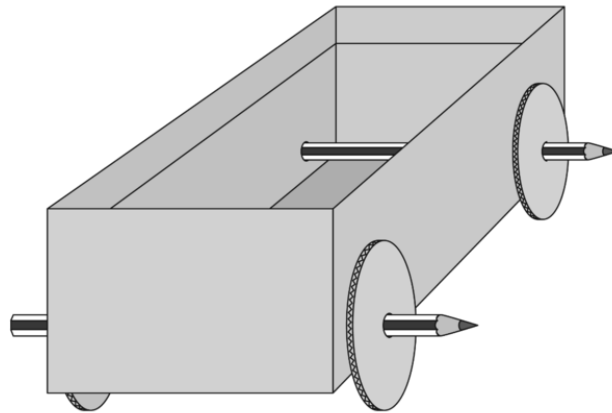

Year 3: In English, we have started our new non-fiction text on rocks. We've started to discuss what features our text has and what ours will look like when we come to write our own version. We have been learning part of the information using a story map and have used actions to help remind us of the text. In maths, we've continued learning how to use column addition and how to exchange across the ones and tens. We've been resilient in every lesson.

$$\begin{array}{r} 11 \quad 16 \quad 3 \\ 5 \quad 4 \quad 9 \\ + 2 \quad 7 \quad 6 \\ \hline 9 \quad 8 \quad 8 \end{array}$$

Year 4: We have been doing a different kind of learning this week and have completed week one of our swimming lessons. We have started to learn about measure in maths and we have started learning about the Roman Empire. Well done for all your hard work this week.



Year 5/6: We have begun our new DT unit on structures. We researched different tent structures and are really excited to build models of these in the coming weeks. In English, we have written a class biography about J K Rowling; we learned lots of interesting facts!!



A big well done to our learners of the week.



Foundation: G.Bunt

Year 1: M.Honeywill

Year 2: A.Taylor

Year 3: T.Ludgate

Year 4: J.Medway-Gould

Year 5: L.Gray

Year 6: L.Hogg



Well done to Year 4 on getting 100% attendance this week.

Dates to remember!!!

04/11/2024 - 21/11/2024 - Year 4 Swimming

11/11/2024 - Remembrance day

12/11/2024 - Wear odd socks day - Anti bullying week

13/11/2024 - Parents evening - All classes

14/11/2024 - Parents evening - All classes

15/11/2024 - Children in need - Mufti day - wear something spotty - Donations via Parent Pay.

06/12/2024 - Christmas Fayre

09/12/2024 - Christingle Service

11/12/2024 - Christmas dinner and jumper day

17/12/2024 - EYFS & KS1 Christmas play 2:30pm (tickets can be purchased closer to the time)

18/12/2024 - KS2 Christmas play 2:30pm & 4:30pm (tickets can be purchased closer to the time)

19/12/2024 - Class Christmas parties

20/12/2024 - Last day of term.



Lunch Menu 2



| Monday | | | | |
|-------------------------|-----------------------------|---------------------------------|---|-----------------------|
| Main | Vegetarian | Sides | Jacket Potato | Dessert |
| Cheese and tomato pizza | Tomato and basil pasta bake | Beans Sweetcorn Spaghetti | <ul style="list-style-type: none"> Cheese Beans Tuna | Crispy chocolate cake |



| Tuesday | | | | |
|----------|---------------------|--|---|--------------------------|
| Main | Vegetarian | Sides | Jacket Potato | Dessert |
| Sausages | Vegetarian sausages | Mashed potato Cauliflower Beans Green beans | <ul style="list-style-type: none"> Cheese Beans Tuna | Peach sponge and custard |



| Wednesday | | | | |
|---------------|-------------|--|---|------------|
| Main | Vegetarian | Sides | Jacket Potato | Dessert |
| Roast Chicken | Quorn Roast | Roast potatoes Broccoli Carrots Beans | <ul style="list-style-type: none"> Cheese Beans Tuna | Artic roll |





| Thursday | | | | |
|----------|-------------------|---------------------------------|---|------------|
| Main | Vegetarian | Sides | Jacket Potato | Dessert |
| Lasagne | Vegetable lasagne | Beans Mixed Veg Sweetcorn | <ul style="list-style-type: none"> Cheese Beans Tuna | Shortbread |



| Friday | | | | |
|---------------|-----------------|----------------------------------|---|-----------|
| Main | Vegetarian | Sides | Jacket Potato | Dessert |
| Battered fish | Cheese omelette | Beans Peas Spaghetti hoops | <ul style="list-style-type: none"> Cheese Beans Tuna | Flap Jack |

Available each day

- Seasonal vegetables
- Milk
- Water

Information on term time holidays from West Country Schools Trust.



WESTCOUNTRY
SCHOOLS TRUST

ATTENDANCE

WHAT THE NEW RULES MEAN FOR ME

1 I'm a single parent of one child and we want to go on holiday for a week.

Your holiday will not be authorised and you must talk to the school before you book anything. Because your child will miss 5 school days you will be given a penalty notice fine. The fine is £160 but if you pay it in 21 days it will be reduced to £80.

£160



2 FOR EVERY CHILD A PENALTY IS GIVEN.

IRREGULAR ATTENDANCE
10 IN 10 **5**

If your child is absent for 10 or more sessions in 10 weeks and their absences are unauthorised. The school will consider prosecution.

1 Day = **2** Sessions



+ £160 + £160 + £160 + £160
4 children & 1 parent = £640
Reduced to £320 if paid in 21 days

3 FOR A FAMILY OF TWO PARENTS

+ £160 + £160 + £160 + £160

4 children & 2 parents = £1280
Reduced to £640 if paid in 21 days



If in any period of not more than 3 years, your child has a 2nd and 3rd leave of absence or pattern of irregular attendance...

4

2ND TIME

2 parents and 1 child = £320
2 children = 640
3 children = 960
4 children = 1280

3RD TIME

A penalty notice fine will not be given. Instead, your case will be taken to court. A magistrate can fine each parent £2500 for each child
1 parent & 4 children = £10,000
2 parents & 4 children = £20,000



No discount for early payment

WeST Term Dates 2024-2025

WeST Term Dates 2024 to 2025

Agreed for wider distribution

| Aug 2024 | | | | | | | Sep 2024 | | | | | | | Oct 2024 | | | | | | |
|----------|----|----|----|----|----|----|----------|----|----|----|----|----|----|----------|----|----|----|----|----|----|
| M | T | W | T | F | S | S | M | T | W | T | F | S | S | M | T | W | T | F | S | S |
| | | | 1 | 2 | 3 | 4 | | | | | | | 1 | 1 | 2 | 3 | 4 | 5 | 6 | |
| 5 | 6 | 7 | 8 | 9 | 10 | 11 | 2 | 3 | 4 | 5 | 6 | 7 | 8 | 7 | 8 | 9 | 10 | 11 | 12 | 13 |
| 12 | 13 | 14 | 15 | 16 | 17 | 18 | 9 | 10 | 11 | 12 | 13 | 14 | 15 | 14 | 15 | 16 | 17 | 18 | 19 | 20 |
| 19 | 20 | 21 | 22 | 23 | 24 | 25 | 16 | 17 | 18 | 19 | 20 | 21 | 22 | 21 | 22 | 23 | 24 | 25 | 26 | 27 |
| 26 | 27 | 28 | 29 | 30 | 31 | | 23 | 24 | 25 | 26 | 27 | 28 | 29 | 28 | 29 | 30 | 31 | | | |
| | | | | | | | 30 | | | | | | | | | | | | | |

| Nov 2024 | | | | | | | Dec 2024 | | | | | | | Jan 2025 | | | | | | |
|----------|----|----|----|----|----|----|----------|----|----|----|----|----|----|----------|----|----|----|----|----|----|
| M | T | W | T | F | S | S | M | T | W | T | F | S | S | M | T | W | T | F | S | S |
| | | | 1 | 2 | 3 | | | | | | | 1 | | | | 1 | 2 | 3 | 4 | 5 |
| 4 | 5 | 6 | 7 | 8 | 9 | 10 | 2 | 3 | 4 | 5 | 6 | 7 | 8 | 6 | 7 | 8 | 9 | 10 | 11 | 12 |
| 11 | 12 | 13 | 14 | 15 | 16 | 17 | 9 | 10 | 11 | 12 | 13 | 14 | 15 | 13 | 14 | 15 | 16 | 17 | 18 | 19 |
| 18 | 19 | 20 | 21 | 22 | 23 | 24 | 16 | 17 | 18 | 19 | 20 | 21 | 22 | 20 | 21 | 22 | 23 | 24 | 25 | 26 |
| 25 | 26 | 27 | 28 | 29 | 30 | | 23 | 24 | 25 | 26 | 27 | 28 | 29 | 27 | 28 | 29 | 30 | 31 | | |
| | | | | | | | 30 | 31 | | | | | | | | | | | | |

| Feb 2025 | | | | | | | Mar 2025 | | | | | | | Apr 2025 | | | | | | |
|----------|----|----|----|----|----|----|----------|----|----|----|----|----|----|----------|----|----|----|----|----|----|
| M | T | W | T | F | S | S | M | T | W | T | F | S | S | M | T | W | T | F | S | S |
| | | | | 1 | 2 | | | | | | 1 | 2 | | 1 | 2 | 3 | 4 | 5 | 6 | |
| 3 | 4 | 5 | 6 | 7 | 8 | 9 | 3 | 4 | 5 | 6 | 7 | 8 | 9 | 7 | 8 | 9 | 10 | 11 | 12 | 13 |
| 10 | 11 | 12 | 13 | 14 | 15 | 16 | 10 | 11 | 12 | 13 | 14 | 15 | 16 | 14 | 15 | 16 | 17 | 18 | 19 | 20 |
| 17 | 18 | 19 | 20 | 21 | 22 | 23 | 17 | 18 | 19 | 20 | 21 | 22 | 23 | 21 | 22 | 23 | 24 | 25 | 26 | 27 |
| 24 | 25 | 26 | 27 | 28 | | | 24 | 25 | 26 | 27 | 28 | 29 | 30 | 28 | 29 | 30 | | | | |
| | | | | | | | 31 | | | | | | | | | | | | | |

| May 2025 | | | | | | | Jun 2025 | | | | | | | Jul 2025 | | | | | | |
|----------|----|----|----|----|----|----|----------|----|----|----|----|----|----|----------|----|----|----|----|----|----|
| M | T | W | T | F | S | S | M | T | W | T | F | S | S | M | T | W | T | F | S | S |
| | | | 1 | 2 | 3 | 4 | | | | | | 1 | | 1 | 2 | 3 | 4 | 5 | 6 | |
| 5 | 6 | 7 | 8 | 9 | 10 | 11 | 2 | 3 | 4 | 5 | 6 | 7 | 8 | 7 | 8 | 9 | 10 | 11 | 12 | 13 |
| 12 | 13 | 14 | 15 | 16 | 17 | 18 | 9 | 10 | 11 | 12 | 13 | 14 | 15 | 14 | 15 | 16 | 17 | 18 | 19 | 20 |
| 19 | 20 | 21 | 22 | 23 | 24 | 25 | 16 | 17 | 18 | 19 | 20 | 21 | 22 | 21 | 22 | 23 | 24 | 25 | 26 | 27 |
| 26 | 27 | 28 | 29 | 30 | 31 | | 23 | 24 | 25 | 26 | 27 | 28 | 29 | 28 | 29 | 30 | 31 | | | |
| | | | | | | | 30 | | | | | | | | | | | | | |

Key: Peach - holiday periods; light green - weekends; blue - Trust NPD; yellow - School NPD

Important dates

Autumn Term Dates: Monday 2 September to Friday 25 October, then Monday 4 November to Friday 20 December

Term 1: 40 days (inc. School NPD Mon 2 Sept and WeST NPD Tues 3 Sept)

Term 2: 35 days

Spring Term Dates: Monday 6 January to Friday 14 February, then Monday 24 February to Friday 4 April

Term 3: 30 days (inc. School NPD Monday 6 January)

Term 4: 30 days

Summer Term Dates: Tuesday 22 April to Friday 23 May, then Monday 2 June to Tuesday 22 July (Note: NPDs on Mo 21 and Tu 22 Jul '25 are

disaggregated for staff twilight training throughout the year. The last day of the academic year for students and staff is Friday 18 July 2025)

Term 5: 23 days

Term 6: 37 days

WeST Term Dates 2025-2026

WeST Term Dates 2025-2026

| Aug 2025 | | | | | | | Sep 2025 | | | | | | | Oct 2025 | | | | | | |
|----------|----|----|----|----|----|----|----------|----|----|----|----|----|----|----------|----|----|----|----|----|----|
| M | T | W | T | F | S | S | M | T | W | T | F | S | S | M | T | W | T | F | S | S |
| | | | | 1 | 2 | 3 | 1 | 2 | 3 | 4 | 5 | 6 | 7 | 6 | 7 | 8 | 9 | 10 | 11 | 12 |
| 4 | 5 | 6 | 7 | 8 | 9 | 10 | 8 | 9 | 10 | 11 | 12 | 13 | 14 | 13 | 14 | 15 | 16 | 17 | 18 | 19 |
| 11 | 12 | 13 | 14 | 15 | 16 | 17 | 15 | 16 | 17 | 18 | 19 | 20 | 21 | 20 | 21 | 22 | 23 | 24 | 25 | 26 |
| 18 | 19 | 20 | 21 | 22 | 23 | 24 | 22 | 23 | 24 | 25 | 26 | 27 | 28 | 27 | 28 | 29 | 30 | 31 | | |
| 25 | 26 | 27 | 28 | 29 | 30 | | 29 | 30 | | | | | | | | | | | | |

| Nov 2025 | | | | | | | Dec 2025 | | | | | | | Jan 2026 | | | | | | |
|----------|----|----|----|----|----|----|----------|----|----|----|----|----|----|----------|----|----|----|----|----|----|
| M | T | W | T | F | S | S | M | T | W | T | F | S | S | M | T | W | T | F | S | S |
| | | | | 1 | 2 | | 1 | 2 | 3 | 4 | 5 | 6 | 7 | 5 | 6 | 7 | 8 | 9 | 10 | 11 |
| 3 | 4 | 5 | 6 | 7 | 8 | 9 | 8 | 9 | 10 | 11 | 12 | 13 | 14 | 12 | 13 | 14 | 15 | 16 | 17 | 18 |
| 10 | 11 | 12 | 13 | 14 | 15 | 16 | 15 | 16 | 17 | 18 | 19 | 20 | 21 | 19 | 20 | 21 | 22 | 23 | 24 | 25 |
| 17 | 18 | 19 | 20 | 21 | 22 | 23 | 22 | 23 | 24 | 25 | 26 | 27 | 28 | 26 | 27 | 28 | 29 | 30 | | |
| 24 | 25 | 26 | 27 | 28 | 29 | 29 | 29 | 30 | 31 | | | | | | | | | | | |

| Feb 2026 | | | | | | | Mar 2026 | | | | | | | Apr 2026 | | | | | | |
|----------|----|----|----|----|----|----|----------|----|----|----|----|----|----|----------|----|----|----|----|----|----|
| M | T | W | T | F | S | S | M | T | W | T | F | S | S | M | T | W | T | F | S | S |
| | | | | | 1 | | | | | | 1 | | 6 | 7 | 8 | 9 | 10 | 11 | 12 | |
| 2 | 3 | 4 | 5 | 6 | 7 | 8 | 2 | 3 | 4 | 5 | 6 | 7 | 8 | 13 | 14 | 15 | 16 | 17 | 18 | 19 |
| 9 | 10 | 11 | 12 | 13 | 14 | 15 | 9 | 10 | 11 | 12 | 13 | 14 | 15 | 20 | 21 | 22 | 23 | 24 | 25 | 26 |
| 16 | 17 | 18 | 19 | 20 | 21 | 22 | 16 | 17 | 18 | 19 | 20 | 21 | 22 | 27 | 28 | 29 | 30 | | | |
| 23 | 24 | 25 | 26 | 27 | 28 | | 23 | 24 | 25 | 26 | 27 | 28 | 29 | | | | | | | |
| | | | | | | | 30 | 31 | | | | | | | | | | | | |

| May 2026 | | | | | | | Jun 2026 | | | | | | | Jul 2026 | | | | | | |
|----------|----|----|----|----|----|----|----------|----|----|----|----|----|----|----------|----|----|----|----|----|----|
| M | T | W | T | F | S | S | M | T | W | T | F | S | S | M | T | W | T | F | S | S |
| | | | | 1 | 2 | 3 | 1 | 2 | 3 | 4 | 5 | 6 | 7 | 6 | 7 | 8 | 9 | 10 | 11 | 12 |
| 4 | 5 | 6 | 7 | 8 | 9 | 10 | 8 | 9 | 10 | 11 | 12 | 13 | 14 | 13 | 14 | 15 | 16 | 17 | 18 | 19 |
| 11 | 12 | 13 | 14 | 15 | 16 | 17 | 15 | 16 | 17 | 18 | 19 | 20 | 21 | 20 | 21 | 22 | 23 | 24 | 25 | 26 |
| 18 | 19 | 20 | 21 | 22 | 23 | 24 | 22 | 23 | 24 | 25 | 26 | 27 | 28 | 27 | 28 | 29 | 30 | 31 | | |
| 25 | 26 | 27 | 28 | 29 | 30 | 31 | 29 | 30 | | | | | | | | | | | | |

| Key | |
|---|-----------------|
| | Holiday periods |
| | Bank holidays |
| | Weekends |
| | Trust NPDs |
| | School NPDs |

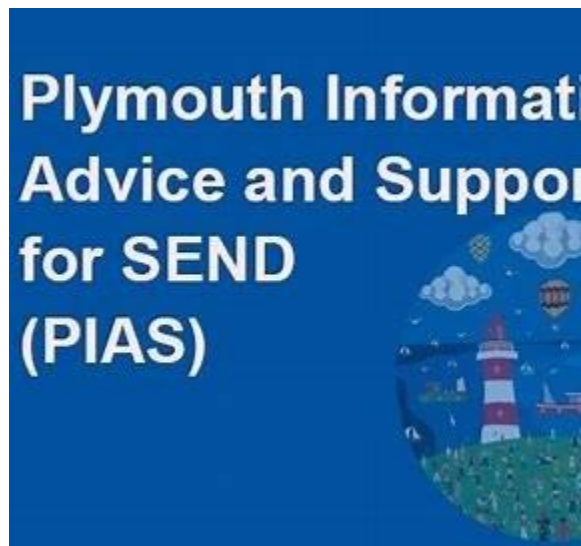

[Plymouth Information Advice and Support for SEND. - Supplying you with information, advice and support \(plymouthias.org.uk\)](http://plymouthias.org.uk)